

THINSULEX™

Thinsulex™ complies with Part L by combining the benefits of thin foil insulation with other insulation materials.

Using Thinsulex™ as a platform it is possible to build the required U-value using the BRE U-value calculator. This provides a wide range of options which can be influenced by rafter thickness and width as well as whether rafters are partially or completely exposed.

The general installation instructions on the right provide examples of a number of options.

Should you require more detailed installation instructions please visit our website at www.webdynamics.co.uk or call Thinsulex™ support on 01204 695 666.

THINSULEX™ with PUR

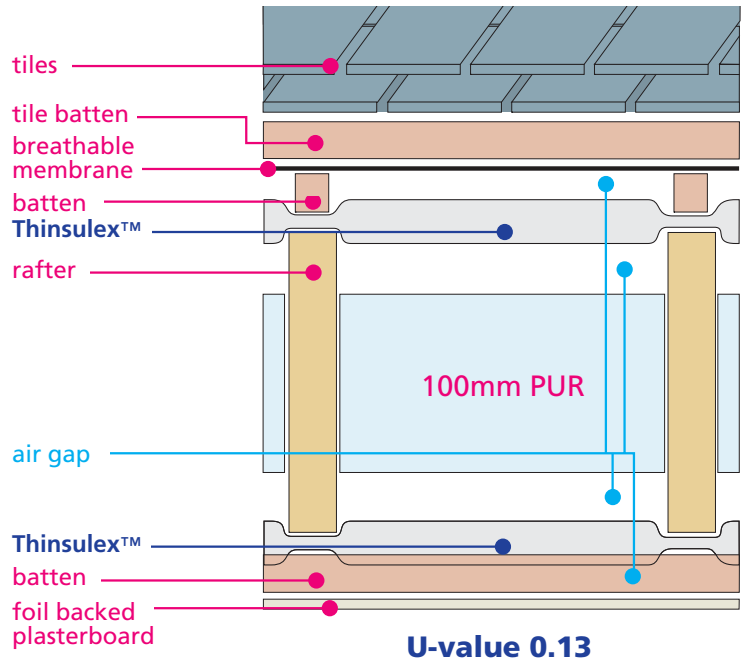

THINSULEX™ with glass wool

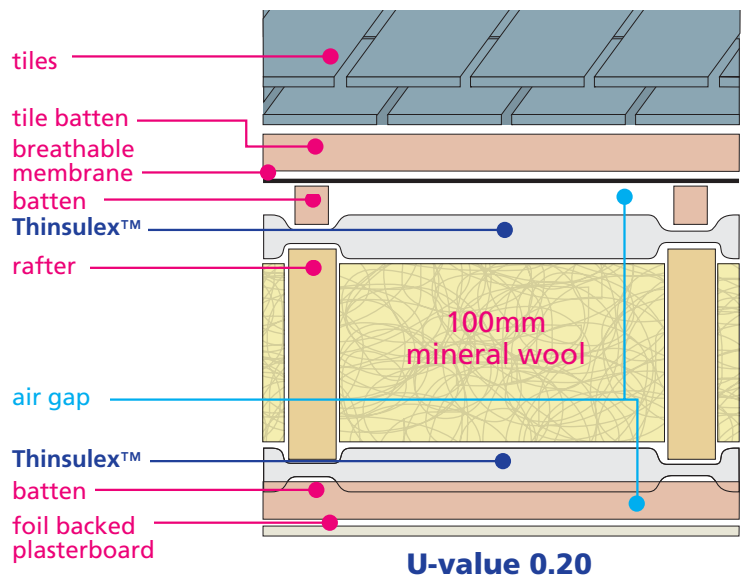

THINSULEX™ with insulated plasterboard

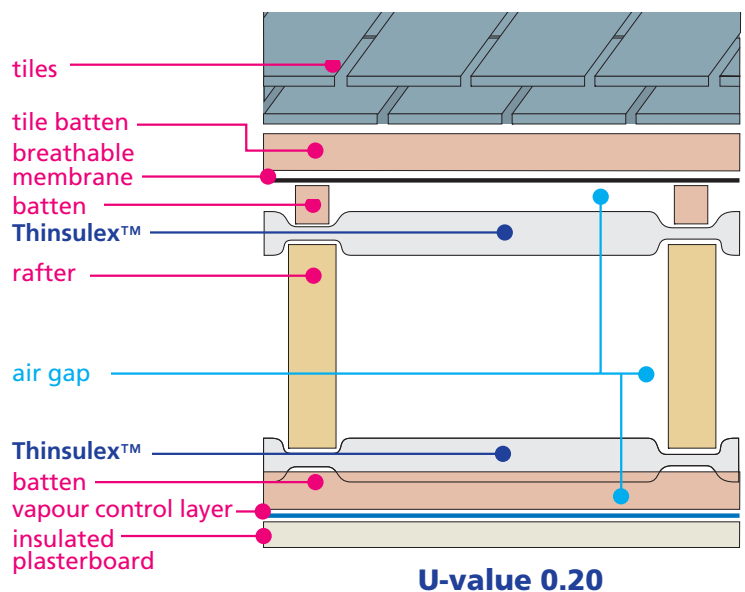

Make sure when installing Thinsulex™ that it does not come into contact with heat sources greater than 80C or electric wiring.



Thinsulex™ has been tested on a guarded hot box with battens in accordance with Part L (incorporating BR443).

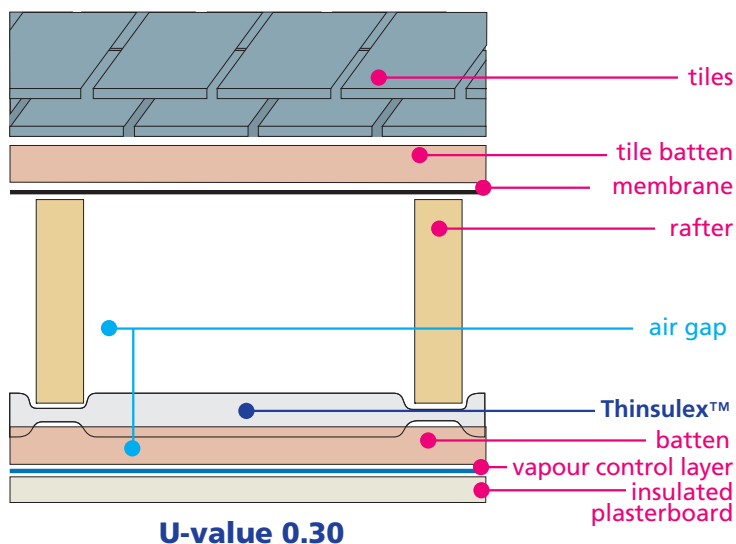
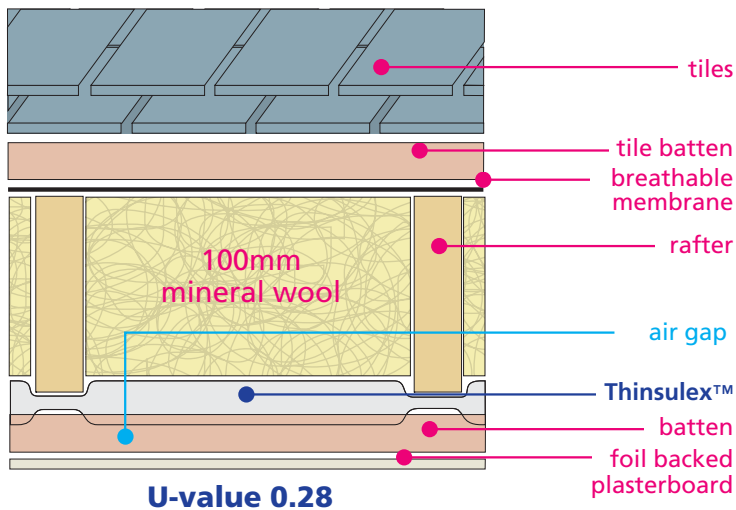
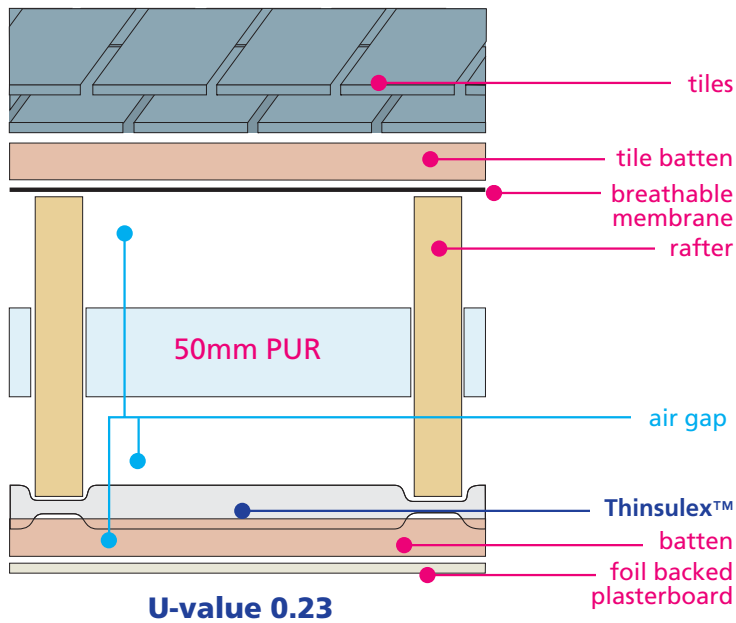

General installation guidelines for Thinsulex™

- ◆ Thinsulex™ can be attached to the rafters by using double sided tape, glue, staples or nails.
- ◆ Thinsulex™ should have a 50mm overlap and be taped along the entire length of the joint with a self-adhesive aluminium foil tape.

For under rafter applications

- ◆ Starting at the ridge and working down, unroll Thinsulex™ parallel to the eaves.
- ◆ Cross batten Thinsulex™ from the ridge downwards with the batten spacing no greater than 600mm. The cross battens should be a minimum of 25mm thick.
- ◆ Finally fix the internal foil backed plasterboard to the cross battens.

For over rafter applications

- ◆ Starting at the eaves and working upwards, unroll Thinsulex™ parallel to the eaves.
- ◆ Fix battens on top and along the line of the rafters.
- ◆ Install breather membrane over the battens.
- ◆ Fix the membrane in place with the tile battens.
- ◆ Tiles/slates should be fitted as soon as possible.

When installing additional insulation

PUR

- ◆ Install the PUR (with a lambda value of 0.023W/mK) in accordance with manufacturers' instructions for an unventilated pitched roof, based on a between rafter application.
- ◆ Retain a 25mm air gap above and below the PUR.

Mineral wool

- ◆ Place the 100mm thick mineral wool/fibre glass (with a lambda value of 0.044W/mK) in between the rafters and directly on top of the Thinsulex™.

Performance considerations:

- ◆ As Thinsulex™ performs as a vapour barrier, it is advisable to utilise a breather membrane, preferably reflective, in your roof system. This will eliminate the need for additional ventilation.
- ◆ When installing PUR to attain the U-value of 0.16W/m²K a minimum rafter depth of 150mm is required.
- ◆ When using insulated plasterboard, a vapour barrier must be installed.