

THINSULEX

MULTIFOIL INSULATION

RafterFit

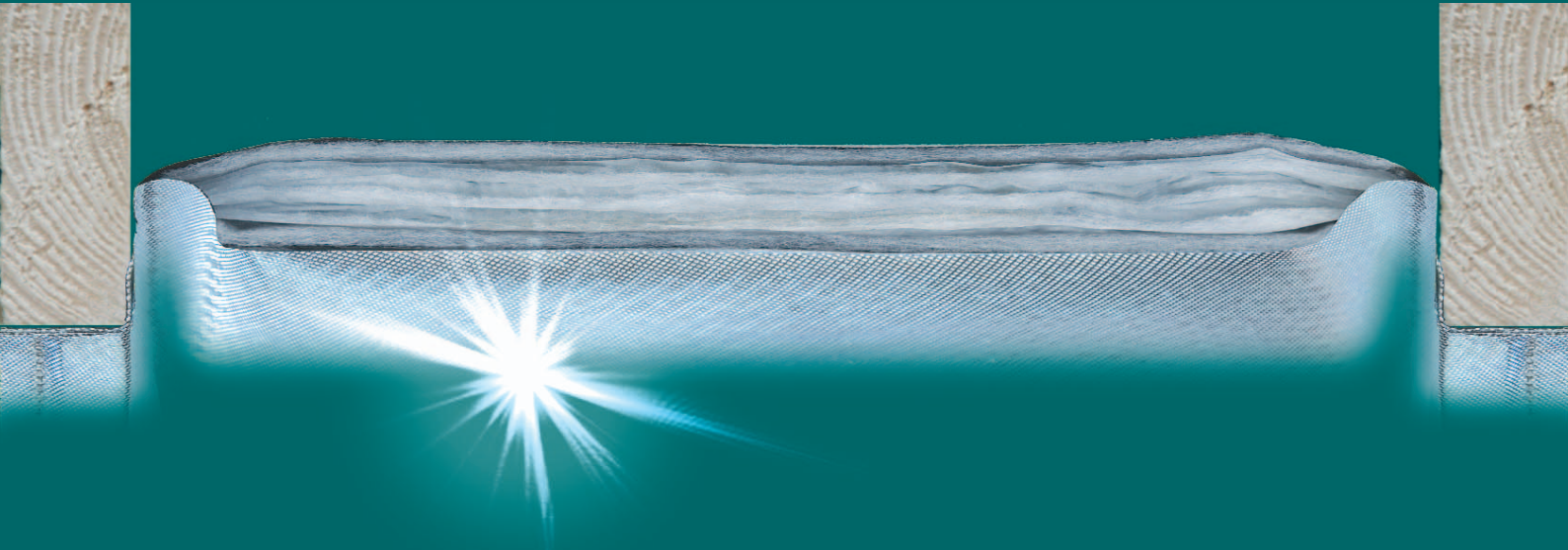

The brighter way to insulate

Installation instructions



The multi-foil system
certified to achieve 0.2
when installed according to BBA certificate No 06/4379

Installing RafterFit™

RafterFit can be used in 38 or 50 x 100mm rafters at 400mm centres.



Measure the length of the rafter that needs insulating.

Cut a length of RafterFit equal to this length + 50mm.

Place the RafterFit against the rafters with a 25mm overlap at top and bottom.

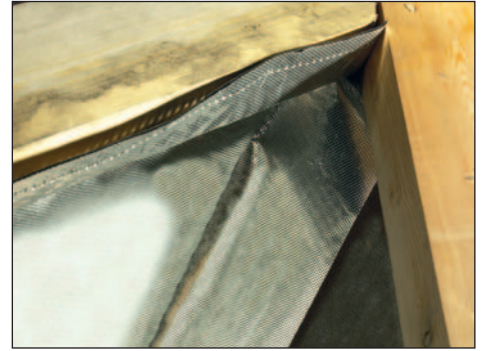

Staple the wings to the bottom edge of each rafter.

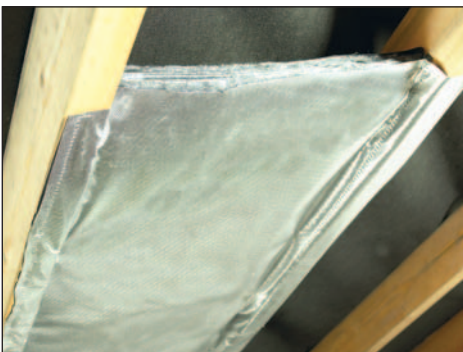

Push the core inside the space and staple to the sides of the rafters.

The RafterFit should run taut across the rafters – this ensures that a 50mm air space is maintained above the RafterFit, and a 20mm air space below.



Install RafterFit into the next rafter space in exactly the same way.

The flaps of adjacent strips of RafterFit should overlap along the edge of the rafter.

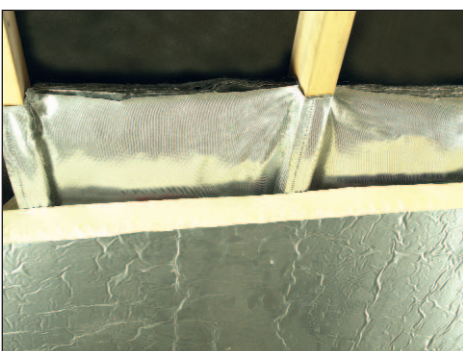
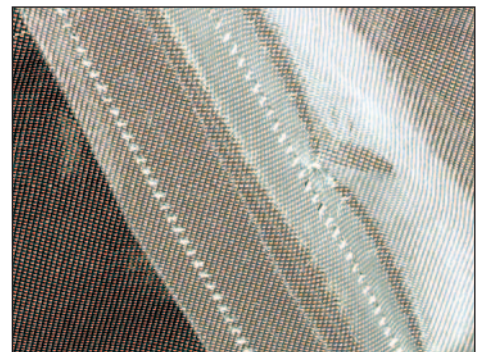

Fit rigid board below the rafter

Fit 12.5mm standard plasterboard beneath the rigid board

RafterFit: 0.2 details

A

RafterFit + 70mm rigid board without battens

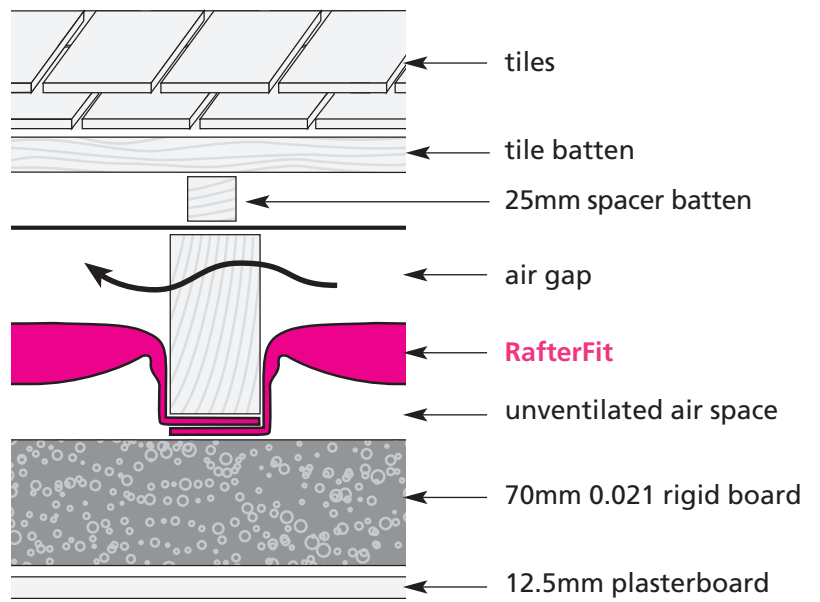
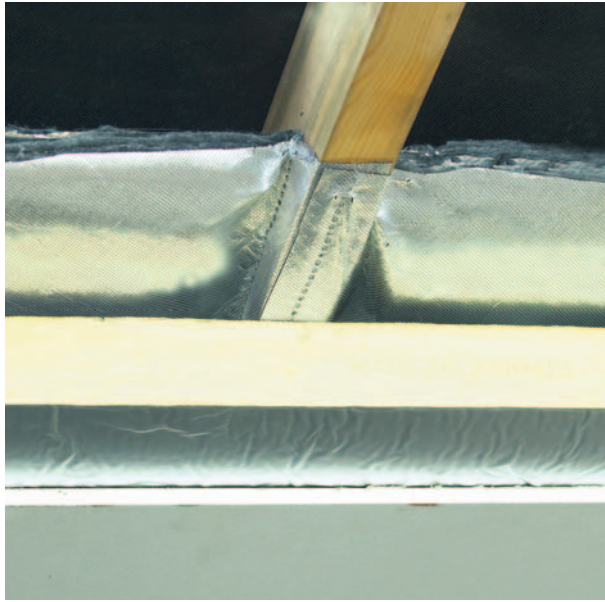

B

RafterFit + 70mm rigid board with battens

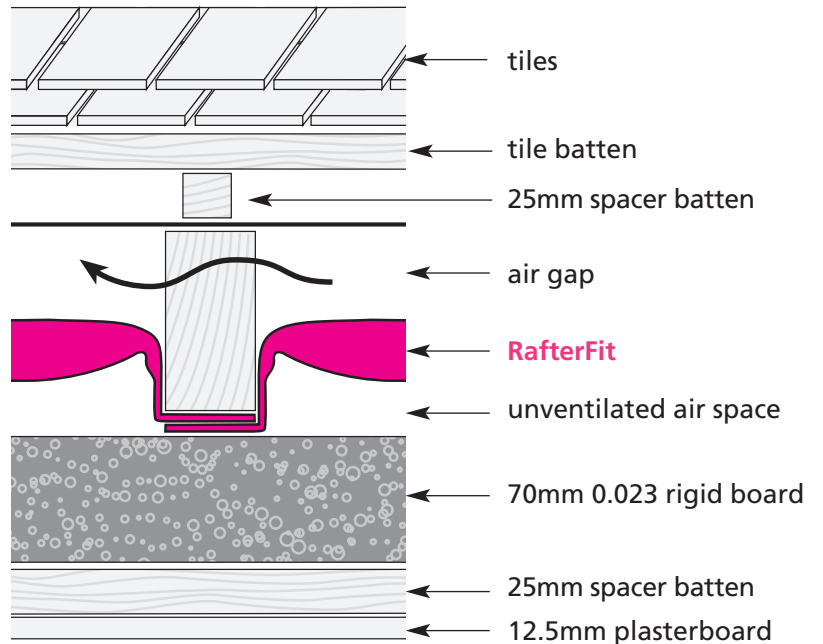
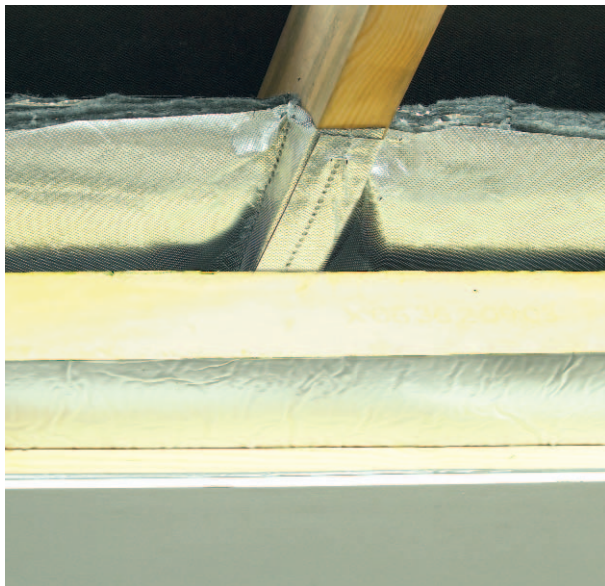

KEY

-  1F felt
-  RafterFit

NOTE: it is important to maintain unobstructed air spaces

IMPORTANT NOTE

Page 28 of Part L 1B states:

RENEWAL OF ROOF COVERINGS
Target U value 0.2 W/m².K

Practical considerations with respect to an increase in structural thickness (particularly in terraced dwellings) may necessitate a lower performance target.

In circumstances Building Control allow a lower U-value please contact Web Dynamics Ltd for a U-value calculation.

GENERAL INSTRUCTIONS

- RafterFit can be installed either way up.
- Protective clothing is not required when handling RafterFit.
- Bare electrical wiring must not be allowed in contact with RafterFit. PVC coated electrical wiring to normal domestic items such as light fittings may come into contact with RafterFit.
- If electrical cables are surrounded by insulation they may need to be de-rated. Guidance should be sought from a qualified electrician.

INSTALLATION PROCEDURE

- Measure the length of the sloping section of the roof from eaves to ridge.
- Cut a piece of RafterFit equal to the length of the sloping section of the roof plus 50mm.
- Position the RafterFit down two adjacent rafters with a 25 mm overlap at top and bottom.
- Staple the edges of the wings along the bottom edge of each rafter. Push the central core of RafterFit up into the rafter space and staple to the inner face of the rafters on each side.
- Ensure that the central core of RafterFit runs straight across the rafter space, and that there is a 50mm air space above and a 20mm air space below the RafterFit.
- Staples should be at least 14mm depth.
- At the ridge, slit the final 25mm of RafterFit between the two welds, tuck the central core inside the rafter space and staple it to the ridge beam. Ensure an airtight seal is made at both the sides and end of the rafter space.
- At junction of roof and wall, slit the final 25mm of RafterFit between the two welds, tuck the central core inside the rafter space and staple it to the top of the wall plate. Ensure an airtight seal is made at both the sides and end of the rafter space.

CUTTING

- RafterFit can be cut using a sharp knife with the RafterFit resting on a board, or with scissors.
- When fitting RafterFit around awkward shapes, slit the side with a sharp knife and stuff RafterFit into the space.

Optimising internal living space

L1B states that: "Practical considerations with respect to an increase in structural thickness (particularly in terraced dwellings) may necessitate a lower performance target."

The table below sets out U-values that can be achieved using RafterFit with different thicknesses of rigid board beneath rafters.

TAPING

- Short lengths of RafterFit can be joined together with a suitable tape. Thinsulex tape or Henkel All-Purpose Silver Duck tape are recommended.
- Pieces of RafterFit to be joined should be taped on both sides on a flat surface before installation.

AIR LAYERS

- Unventilated air layers form an important part of the RafterFit Insulation System. If the air spaces are omitted, whilst there is no danger of condensation, the overall thermal performance of the structure will decrease, and the U value will be higher. Additional insulation may be needed to achieve the desired U-value for the roof

ADDITIONAL INSULATION

- Install additional insulation according to manufacturers instructions.

STORAGE

- RafterFit rolls must be stored on a flat dry surface, protected from weather and direct sunlight.
- Ensure when installing RafterFit that it does not come into contact with heat sources above 80°C.

VAPOUR CONTROL AND VENTILATION

- Where RafterFit is fitted below rafters it also performs as an effective vapour barrier, preventing water vapour from the house from penetrating the roof structure and possibly condensing on a cold surface. No additional vapour barrier is required.
- If a non-breathable (or 1F type) membrane is in place, then a 50mm ventilated air space beneath the felt is required.
- If in any doubt about possible harmful condensation, contact Building Control for guidance.

ACHIEVING BETTER U-VALUES

- U-values lower than those given in the examples may be required to meet SAP targets or simply to provide a better insulated building. These can be achieved by using a greater thickness of additional insulation.

thickness	λ 0.023 38mm batten	λ 0.021 No batten	λ 0.023 No batten
40mm	0.27	0.29	0.30
50mm	0.24	0.25	0.27
60mm	0.22	0.23	0.24
70mm	0.20	0.20	0.22