



Kingspan Insulation Limited

Pembridge
Leominster
Herefordshire HR6 9LA
Tel: 01544 388601 Fax: 01544 388888
e-mail: info@insulation.kingspan.com
website: www.insulation.kingspan.com

**Agrément
Certificate
No 94/3047**
Third issue*

Designated by Government
to issue
European Technical
Approvals

KOOLTHERM K8 CAVITY BOARD

Isolant pour murs creux
Kerndämmung

Product

- THIS CERTIFICATE RELATES TO KOOLTHERM K8 CAVITY BOARD, A FOIL-FACED RIGID PHENOLIC FOAM BOARD FOR CAVITY WALL INSULATION.
- The product is for use in buildings up to 25 m in height, subject to the conditions contained in the Design Data part of this Certificate.
- The product is installed during construction and is for use as a partial fill board to reduce the thermal transmittance of cavity walls with masonry inner and outer leaves.
- It is essential that the walls are built in accordance with the conditions set out in the Design Data and Installation parts of this Certificate.

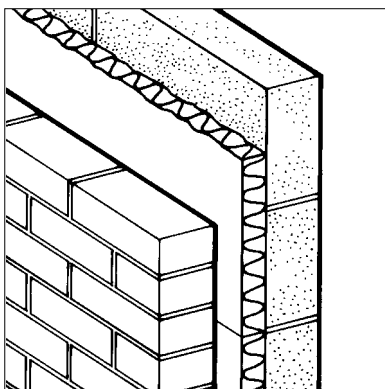

Regulations

1 The Building Regulations 2000 (as amended) (England and Wales)

 The Secretary of State has agreed with the British Board of Agrément the aspects of performance to be used by the BBA in assessing the compliance of cavity wall insulation with the Building Regulations. In the opinion of the BBA, Kooltherm K8 Cavity Board, if used in accordance with the provisions of this Certificate, will meet or contribute to meeting the relevant requirements.

Requirement: B3(4)	Internal fire spread (structure)
Comment:	Walls incorporating the product can meet this Requirement. See sections 8.2 to 8.4 of this Certificate.
Requirement: C2(a)(b)(c)	Resistance to moisture
Comment:	Walls incorporating the product can meet this Requirement. See sections 7.2, 10.2, 13.1 and 13.3 of this Certificate. In addition the product may be used in situations where it bridges the dpc. See section 10.1 of this Certificate.
Requirement: L1(a)(i)	Conservation of fuel and power
Comment:	The product can meet this Requirement. See sections 12.3 to 12.6 of this Certificate.
Requirement: Regulation 7	Materials and workmanship
Comment:	The product is acceptable. See section 14 of this Certificate.

2 The Building (Scotland) Regulations 2004

 In the opinion of the BBA, Kooltherm K8 Cavity Board, if used in accordance with the provisions of this Certificate, will satisfy or contribute to satisfying the various Regulations and Mandatory Standards as listed below.

Regulation: 8	Fitness and durability of materials and workmanship
Regulation: 8(1)	Fitness and durability of materials and workmanship
Comment:	The product can contribute to a construction meeting this Regulation. See section 14 and the <i>Installation</i> part of this Certificate.
Regulation: 9	Building standards — construction
Standard: 2.4	Cavities
Comment:	Wall cavities incorporating the product must comply with this Standard, with reference to clauses 2.4.1 ⁽¹⁾ , 2.4.2 ⁽¹⁾ , 2.4.7 ⁽¹⁾ and 2.4.9 ⁽²⁾ . See section 8.4 of this Certificate.
Standard: 3.4	Moisture from the ground
Comment:	The product does not absorb water by capillary action and, therefore, may be used where it bridges the dpc of either leaf, with reference to clause 3.4.5 ⁽¹⁾⁽²⁾ to this Standard. See sections 10.1 of this Certificate.
Standard: 3.10	Precipitation
Comment:	Walls incorporating the product can satisfy this Standard, with reference to clause 3.10.3 ⁽¹⁾⁽²⁾ , provided they comply with sections 7.2, and 10.2 of this Certificate.
Standard: 3.15	Condensation
Comment:	The product can contribute to satisfying this Standard, with reference to clauses 3.15.1 ⁽¹⁾ , 3.15.3 ⁽¹⁾ and 3.15.4 ⁽¹⁾ . See sections 13.2 and 13.3 of this Certificate.

Electronic Copy

Standard: 6.2

Building insulation envelope

Comment:

The product will enable a wall to satisfy or contribute to satisfying the requirements of this Standard, with reference to clauses 6.2.1⁽¹⁾⁽²⁾ (Table 1), 6.2.4⁽¹⁾⁽²⁾ and 6.2.5⁽¹⁾⁽²⁾. See sections 12.7 and 12.8 of this Certificate.

(1) Technical Handbook (Domestic).

(2) Technical Handbook (Non-Domestic).

3 The Building Regulations (Northern Ireland) 2000 (as amended)



In the opinion of the BBA, Kooltherm K8 Cavity Board, if used in accordance with the provisions of this Certificate, will satisfy or contribute to satisfying the various Building Regulations as listed below.

Regulation: B2

Fitness of materials and workmanship

Comment:

The product is acceptable. See section 14 of this Certificate.

Regulation: C4

Resistance to ground moisture and weather

Comment:

Walls incorporating the product can satisfy this Regulation. See sections 7.2, 10.2 and 13.3 of this Certificate. In addition the product may be used where it bridges the dpc. See section 10.1 of this Certificate.

Regulation: E3

Internal fire spread — Structure

Comment:

Walls incorporating the product can satisfy this Regulation. See sections 8.2 to 8.4 of this Certificate.

Regulation: F2(a)(i)

Conservation measures

Comment:

The product can satisfy this Regulation. See sections 12.3 to 12.6 of this Certificate.

4 Construction (Design and Management) Regulations 1994 (as amended) Construction (Design and Management) Regulations (Northern Ireland) 1995 (as amended)

Information in this Certificate may assist the client, planning supervisor, designer and contractors to address their obligations under these Regulations.

See section:

6 *Delivery and site handling* (6.3).

Technical Specification

5 Description

5.1 Kooltherm K8 Cavity Board is manufactured from rigid, closed-cell phenolic foam board, faced with aluminium composite foil on both sides.

5.2 The product is supplied in standard sizes of 1200 mm by 450 mm and in various thicknesses from 17 mm to 100 mm.

5.3 Only insulation retaining fixings approved by the BBA should be used with this product. Names and addresses of suppliers of approved fixings are available from the Certificate holder and the BBA.

5.4 It should be noted that whilst approved ties are suitable for use for insulation retaining purposes, additional vertical twist ties to EN 845-1 : 2003 may be required for structural stability in accordance with BS 5628-3 : 2005 where the overall cavity width exceeds 75 mm.

6 Delivery and site handling

6.1 The product is delivered to site in polythene wrapped packs on non-returnable pallets. Each pack includes a label bearing the manufacturer's trade name, production date, dimensions, and the BBA identification mark incorporating the number

of this Certificate. Where possible, packs should be stored inside. If stored outside, they should be stacked on a flat surface on the pallets or clear of the ground.

6.2 The product must be protected from prolonged exposure to sunlight and should be stored either under cover or protected with light-coloured, opaque polythene sheets.

6.3 The product must not be exposed to naked flame or other ignition sources.

Design Data

7 General

7.1 Kooltherm K8 Cavity Board will be effective in reducing the U value (thermal transmittance) of new external cavity walls with masonry inner and outer leaves (masonry includes clay and calcium silicate bricks, concrete blocks, natural and reconstituted stone blocks). It is essential that such walls are designed and constructed so as to incorporate the normal precautions to prevent moisture penetration.



7.2 Buildings subject to national Building Regulations should be constructed in accordance with the relevant recommendations of BS 5628-3 : 2005. In particular Clause 21 of the Code of Practice *Exclusion of moisture* should be

followed in that the designer selects a construction appropriate to the local wind-driven rain index paying due regard to the design detailing, workmanship and materials to be used. The relevant recommendations of BS 8000-3 : 2001 should also be followed. The relevant recommendations of BS 5628-3 : 2005 should be followed where the wall incorporates stone or cast stone.

7.3 Other buildings not subject to these Regulations should also be built in accordance with BS 5628-3: 2005, and BS 8000-3 : 2001.

7.4 As with all cavity wall insulation, the construction and detailing should comply with good practice as described in the BBA joint publication *Cavity Insulation of Masonry Walls — Dampness Risks and How to Minimise Them*. They are particularly important in areas subject to severe or very severe driving rain.

7.5 The use of cavity battens or boards is strongly recommended to prevent bridging by mortar droppings.

7.6 As with any other form of cavity wall insulation, where buildings need to comply with NHBC Standards or *Zurich Building Guarantee Technical Manual*, Section 4 *Superstructure, external walls*, Sub-section *Thermal insulation*, specifiers should observe the requirements of these documents.

Buildings up to and including 12 m

7.7 Where a residual cavity width of 50 mm or greater is maintained the product can be used in any exposure zone. However, the use of the product does not preclude the need to apply any external render coat or other suitable finish in severe exposure zones where such application would be normal practice.

7.8 The minimum residual cavity width to be maintained during construction must be 25 mm. To achieve this requirement a greater nominal residual cavity width may need to be specified at the design stage to allow for inaccuracies inherent in the building process. The specifier may either:

- design a cavity width by consideration of the dimensional tolerances of the components which make up the wall by reference to the British Standards relating to the bricks, blocks and insulation boards, or use the data from their respective manufacturers. In addition, allowance may need to be made for the quality of available building operatives and the degree of site supervision or control; or
- design a nominal residual cavity width of 50 mm (a residual cavity nominally 50 mm wide will be required by the NHBC where normal standards of tolerance and workmanship are adopted).

Buildings over 12 m and up to and including 25 m

7.9 The width of residual clear cavity to be achieved is to be in excess of 50 mm, and the following requirements apply:

- from ground level, the maximum height of continuous cavity wall must not exceed 12 m; above 12 m, the maximum height of continuous cavity wall must not exceed 7 m. In both cases, breaks should be in the form of continuous horizontal cavity trays discharging to the outside
- the specifier must take extra care when detailing to ensure that the introduction of the insulation does not affect the weather resistance of the wall. More than average site supervision is recommended during installation of the product
- the exposure index does not exceed 120
- where, for structural reasons, the cavity width is reduced, eg by the intrusion of ring beams, a minimum residual cavity width of 25 mm must be maintained and extra care must be taken with fixings and weatherproofing, eg the inclusion of a cavity tray.

8 Behaviour in relation to fire

8.1 The use of the boards does not prejudice the fire resistance properties of the wall. They are unlikely to become ignited within the cavity when used in the context of this Certificate. If fire does penetrate into an unventilated cavity, the amount of air present will be insufficient to support combustion, and flame spread will be minimal.



8.2 The requirements of the Building Regulations relating to fire spread in cavity walls, can be met in buildings of all purpose groups without the need for cavity barriers, provided the construction complies with the provisions detailed in:

England and Wales

Approved Document B, Diagram 32

Northern Ireland

Technical Booklet E, Diagram 3.5.

8.3 A summary of these provisions is given here:

England and Wales and Northern Ireland

- (1) The wall must consist of masonry inner and outer leaves, each at least 75 mm thick.
- (2) The cavity must not be more than 300 mm wide (Northern Ireland only).
- (3) The cavity must be closed at the top of the wall and at the top of any opening.
- (4) In addition to the insulation only the following should be placed in, or exposed to, the cavity:
 - timber lintels, window or door frames, or end of timber joists
 - pipe, conduit or cables
 - dpc, flashing, cavity closer or wall tie

- domestic meter cupboard, provided there are not more than two cupboards to a dwelling, the opening in the outer leaf is not more than 800 mm by 500 mm for each cupboard, and the inner leaf is not penetrated except by a sleeve not more than 80 mm by 80 mm, which is fire-stopped.



8.4 For constructions not covered by sections 8.2 and 8.3, cavity barriers must be provided to comply with:

England and Wales

Approved Document B, Section 10

Scotland

Mandatory Standard 2.4, clause 2.4.1⁽¹⁾

(1) Technical Handbook (Domestic).

Northern Ireland

Technical Booklet E, paragraphs 3.35 to 3.38.

9 Proximity of flues and appliances

When installing the product in close proximity to certain flue pipes and/or heat-producing appliances and subject of national Building Regulations the following provisions are acceptable:

England and Wales

Approved Document J

Scotland

Mandatory Standard 3.19

Northern Ireland

Technical Booklet L.

10 Liquid water penetration



10.1 When the product is used in situations where it bridges the dpc in walls, dampness from the ground will not pass through to the inner leaf provided the cavity wall is detailed in accordance with the requirements and provisions of the national Building Regulations:

England and Wales

Requirement C2(a).

Scotland

Mandatory Standard 3.4, clause 3.4.1⁽¹⁾⁽²⁾.

(1) Technical Handbook (Domestic).

(2) Technical Handbook (Non-Domestic).

Northern Ireland

Technical Booklet C, Section 1.6.

10.2 Constructions built in accordance with BS 5628-3 : 2005 will resist the transfer of precipitation to the inner leaf and satisfy the national Building Regulations:

England and Wales

Requirement C2(b)

Scotland

Mandatory Standard 3.10, clause 3.10.3⁽¹⁾⁽²⁾

(1) Technical Handbook (Domestic).

(2) Technical Handbook (Non-Domestic).

Northern Ireland

Technical Booklet C, Section 2

10.3 In all situations it is particularly important to ensure during installation that:

- wall ties and fixings are installed correctly and are thoroughly clean
- excess mortar is cleaned from the cavity face of the leading leaf and any debris removed from the cavity
- mortar droppings are cleaned from the exposed edges of installed boards
- installation is carried out to the highest level on each wall or the top edge of the insulation is protected by a cavity tray.

11 Water vapour penetration

11.1 The product has a vapour resistance of approximately 244 MNsg^{-1} and therefore will provide a significant resistance to water vapour transmission, and would be considered a vapour control layer as defined in Section 1 of BS 5250 : 2002. Joints between boards will facilitate the passage of water vapour under normal conditions of temperature and humidity.

11.2 If the product is to be used in the external walls of rooms expected to have high humidities, care must be taken to provide adequate permanent ventilation to avoid possible problems from the formation of interstitial condensation in the internal wall leaf.

12 Thermal performance

12.1 Calculations of the thermal transmittance (U value) of specific external wall constructions should be carried out in accordance with BS EN ISO 6946 : 1997 and BRE report (BR 443 : 2006) *Conventions for U-value calculations*, using thermal conductivities as given in Table 1.

Table 1 Thermal conductivity values for K8 cavity

Thickness (mm)	Thermal conductivity ($\text{Wm}^{-2}\text{K}^{-1}$)
15–24	0.024
25–44	0.023
>44	0.022

12.2 The U value of a typical brick and block cavity wall construction will depend on the cavity width and the insulating value of the internal block leaf and finish. Example U values are given in Table 2.

Table 2 Typical cavity wall U values ($\text{Wm}^{-2}\text{K}^{-1}$)⁽¹⁾

Cavity width (mm)	13 mm dense plaster 100 mm dense block ⁽²⁾	Plasterboard on dabs 100 mm AAC block ⁽³⁾
75	0.44	0.33
100	0.34	0.27
125	0.28	0.23

- (1) Assumes fixings correction $\Delta U_f < 3\%$ of nominal U value and 102 mm thick brick outer leaf.
 (2) Block and plaster thermal conductivity $1.28 \text{ Wm}^{-1}\text{K}^{-1}$ and $0.57 \text{ Wm}^{-1}\text{K}^{-1}$ respectively.
 (3) Block and mortar thermal conductivity $0.11 \text{ Wm}^{-1}\text{K}^{-1}$ and $0.88 \text{ Wm}^{-1}\text{K}^{-1}$ respectively.



12.3 Subject to the selection of an appropriate board thickness, cavity width and/or block leaf construction, walls can improve on the Elemental U value of $0.35 \text{ Wm}^{-2}\text{K}^{-1}$ required by the Building Regulations and the value of $0.35 \text{ Wm}^{-2}\text{K}^{-1}$ specified in Table R1 of Appendix R of *The Government's Standard Assessment Procedure for Energy Rating for Dwellings* (SAP 2005) or the Simplified Building Energy Model (SBEM)⁽¹⁾, see Table 2. Therefore, the product can contribute to enabling a building to meet the Target Emission Rate 'average' improvements of 20% (dwellings) and from 23% to 28% (buildings other than dwellings):

England and Wales

As specified in Approved Documents L1A and L2A

Northern Ireland

As specified in Technical Booklets F1 and F2.

- (1) Published by the Department for Communities and Local Government on its website: www.communities.gov.uk

12.4 The product can maintain, or contribute to maintaining, continuity of thermal insulation at junctions between the external wall and other building elements. Guidance in this respect, and on limiting heat loss by air infiltration, can be found in:

England and Wales

Limiting thermal bridging and air leakage : Robust construction details for dwellings and similar buildings TSO 2002.

Northern Ireland

Accredited Construction Details (Version 1.0).

- (1) Published by the Department for Communities and Local Government on its website: www.communities.gov.uk

12.5 Compliance with the guidance referred to in section 12.3 including airtightness measures will allow the use of the default psi values from Table 3 of BRE Information Paper IP 1/06 *Assessing the effects of thermal bridging at junctions and around openings* and Table K1 of *The Government's Standard Assessment Procedure for Energy Rating of Dwellings* (SAP 2005), in Target Emission Rate calculations to SAP 2005 or the Simplified Building Energy Model (SBEM)⁽¹⁾.

- (1) Published by the Department for Communities and Local Government on its website: www.communities.gov.uk

12.6 When installed in walls of existing buildings, the product can meet, or contribute to meet, the relevant requirements of the following guidance documents:

England and Wales

As specified in Approved Documents L1B, section 2 and L2B, section 3.

Northern Ireland

As specified in Technical Booklets F1 and F2, section 3.



12.7 Subject to the selection of an appropriate cavity width and/or block leaf construction, walls can satisfy the Elemental Target U value of $0.30 \text{ Wm}^{-2}\text{K}^{-1}$ specified in the Technical Handbook⁽¹⁾⁽²⁾, clause 6.2.1, Table 1.

- (1) Technical Handbook (Domestic).
 (2) Technical Handbook (Non-Domestic).

12.8 The product can maintain, or contribute to maintaining, continuity of thermal insulation at junctions between the external wall and other building elements. Guidance in BRE report (BR 262 : 2002) *Thermal insulation : avoiding risks* is acceptable.

13 Condensation

Surface condensation



13.1 Walls will limit the risk of surface condensation adequately when the thermal transmittance (U value) does not exceed $0.7 \text{ Wm}^{-2}\text{K}^{-1}$ at any point, and the junctions with floors, roofs and openings are designed in accordance with *Limiting thermal bridging and air leakage : Robust construction details for dwellings and similar buildings* TSO 2002 or the BRE Information Paper IP 1/06.



13.2 For buildings in Scotland, other constructions will also be acceptable where the thermal transmittance (U value) of the wall does not exceed $1.2 \text{ Wm}^{-2}\text{K}^{-1}$ at any point and openings and junctions with other elements comply with the guidance given in Section 8 of BS 5250 : 2002, BRE report (BR 262 : 2002) or Technical Booklet⁽¹⁾⁽²⁾, Annex 6D, of the Scottish Building Regulations.

- (1) Technical Handbook (Domestic).
 (2) Technical Handbook (Non-Domestic).

Interstitial condensation



13.3 Walls will limit the risk of interstitial condensation adequately when they are designed and constructed in accordance with BS 5250 : 2002 (Section 8 and Annex D).

14 Durability



The product is stable, rot-proof and durable, and will remain effective as an insulation system for the life of the building, provided it is installed in accordance with this Certificate.

Installation

15 General

The walls are constructed leading with either the inner or outer leaf. It is recommended that the inner leaf be constructed ahead of the outer leaf, as Kooltherm K8 Cavity Board fastened to the cavity face of the inner leaf gives a slightly enhanced thermal performance.

16 Procedure

16.1 A section of the inner leaf is built with the first row of wall ties, at approximately 600 mm horizontal spacing, where the insulation is to begin. It is recommended that the wall ties are not placed directly on the damp-proof course. The first run of boards may commence below the damp-proof course level to provide some edge insulation for the floor (see Figure 1).

Figure 1 Installation of Kooltherm K8 Cavity Board

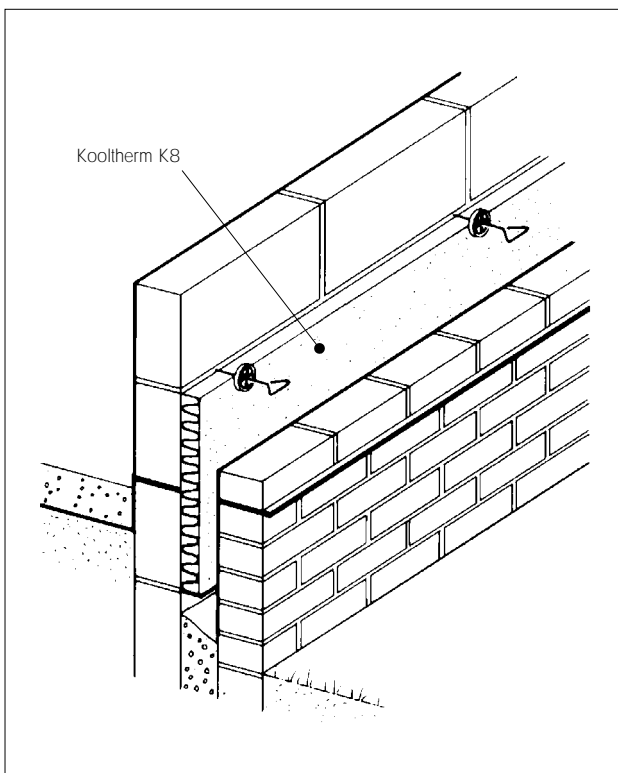

16.2 The leading leaf is built up to the required height, with wall ties placed at a vertical height of 450 mm. Excess mortar is cleaned from the cavity face of the leading leaf, and the boards are placed on the wall ties, behind the retaining clips, to form a closely butt-jointed run.

16.3 The second row of wall ties is fitted to retain the tops of the boards. It is essential that all wall ties slope downwards towards the outer leaf (see Figure 2) and at centres not exceeding 900 mm to ensure that each board is secured at a minimum of three points. Additional ties may be required to satisfy the structural requirements of BS 5628-3 : 2005 and/or to ensure adequate retention of boards or cut pieces.

Figure 2 Installation of wall ties

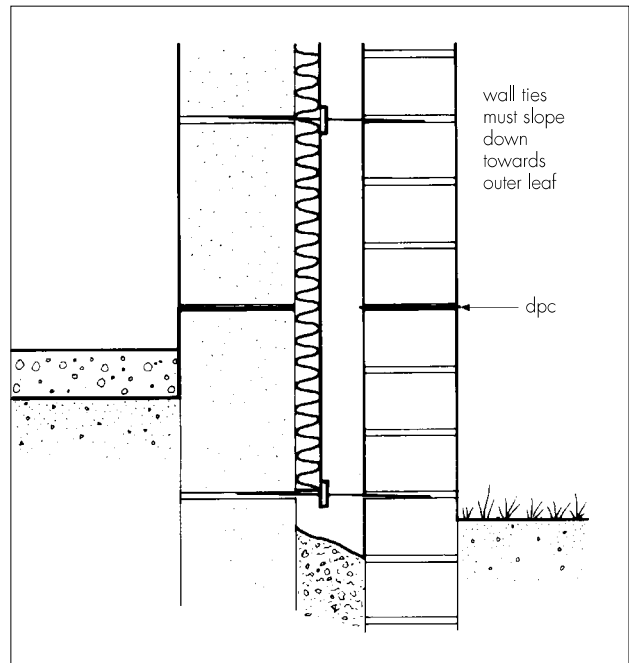

16.4 The other leaf is built up to the level of the top of the boards.

16.5 Progressive staggering of boards and wall ties as construction proceeds should be in accordance with the manufacturer's recommendations.

Mortar droppings

16.6 After each section of the leading leaf is built, excess mortar should be removed from the cavity face and mortar droppings cleaned from exposed edges of the installed board, before installation of the next run of boards. Use of a cavity board or a cavity batten will protect the installed boards and help to keep the cavity clean as the following leaf is built (see Figures 3 and 4).

Figure 3 Use of cavity board

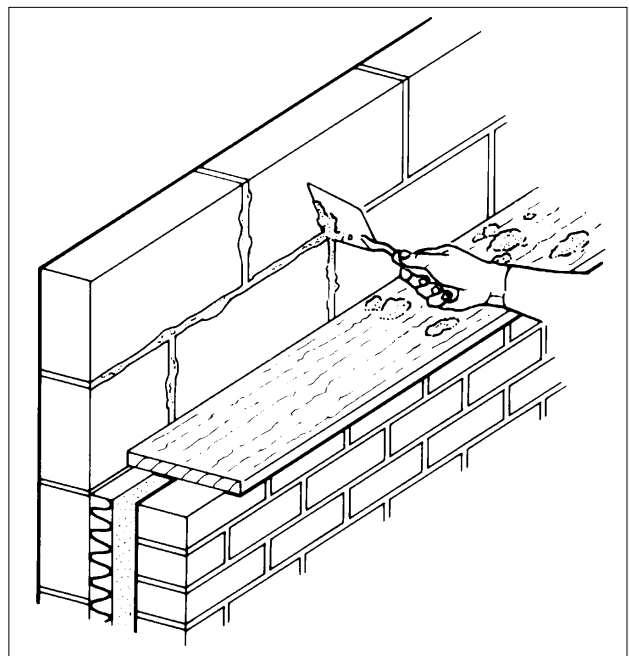
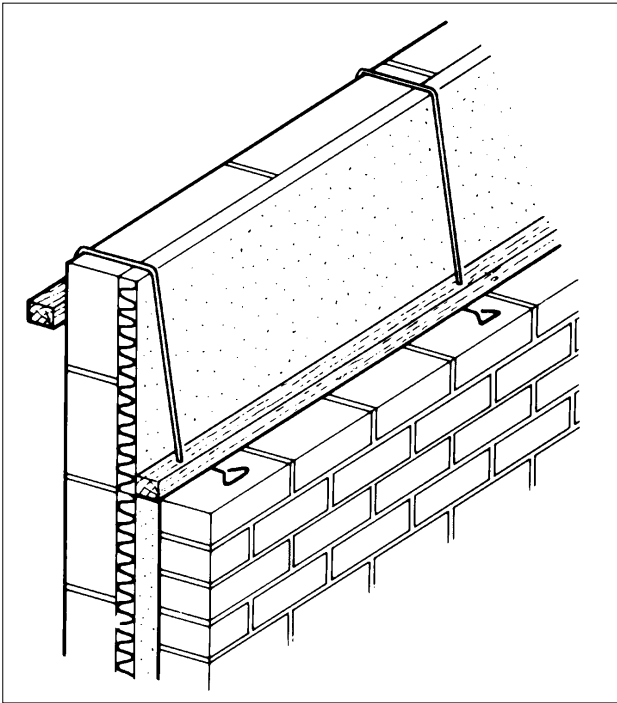

Figure 4 Use of cavity batten



Cut pieces

16.7 Boards can be cut, using a sharp knife or fine-toothed saw, to fit around windows, doors, air bricks. It is essential that cut pieces completely fill the spaces for which they are intended and that no gaps are left in the insulation and the pieces are adequately secured.

Protection

16.8 All building involving the boards, particularly interrupted work, must conform to BS 5628-3 : 2005.

Technical Investigations

The following is a summary of the technical investigations carried out on Kooltherm K8 Cavity Board.

17 Investigations

An examination was made of data relating to:

- density
- weight
- compressive strength
- flexural strength
- dimensional stability with temperature
- dimensional accuracy
- closed cell count
- water absorption
- ignitability
- thermal conductivity (fresh and aged)
- fire propagation
- surface spread of flame
- obscuration
- water vapour resistance.

18 Other investigations

18.1 The manufacturing process was examined, including the methods adopted for quality control, and details were obtained of the quality and composition of the materials used.

18.2 An assessment of the risk of interstitial and surface condensation was made, including calculations in accordance with BS 5250 : 2002.

18.3 The behaviour of the boards in relation to fire was assessed.

Additional Information

The quality management systems of Kingspan Insulation Limited have been assessed and registered as meeting the requirements of BS EN ISO 9001 : 2000 by LPCB Ltd (Certificate No 388).

Bibliography

BS 5250 : 2002 *Code of practice for control of condensation in buildings*

BS 5628-3 : 2005 *Code of practice for the use of masonry — Materials and components, design and workmanship*

BS 8000-3 : 2001 *Workmanship on building sites — Code of practice for masonry*

BS EN ISO 9001 : 2000 *Quality management systems — Requirements*

BS EN ISO 6946 : 1997 *Building components and building elements — Thermal resistance and thermal transmittance — Calculation method*

EN 845-1 : 2003 *Specification for ancillary components for masonry — Ties, tension straps, hangers and brackets*

Conditions of Certification

19 Conditions

19.1 This Certificate:

- relates only to the product/system that is named and described on the front page
- is granted only to the company, firm or person named on the front page — no other company, firm or person may hold or claim any entitlement to this Certificate
- is valid only within the UK
- has to be read, considered and used as a whole document — it may be misleading and will be incomplete to be selective
- is copyright of the BBA
- is subject to English law.

19.2 References in this Certificate to any Act of Parliament, Regulation made thereunder, Directive or Regulation of the European Union, Statutory Instrument, Code of Practice, British Standard, manufacturers' instructions or similar publication, are references to such publication in the form in which it was current at the date of this Certificate.

19.3 This Certificate will remain valid for an unlimited period provided that the product/system and the manufacture and/or fabrication including all related and relevant processes thereof:

- are maintained at or above the levels which have been assessed and found to be satisfactory by the BBA
- continue to be checked as and when deemed appropriate by the BBA under arrangements that it will determine
- are reviewed by the BBA as and when it considers appropriate.

19.4 In granting this Certificate, the BBA is not responsible for:

- the presence or absence of any patent, intellectual property or similar rights subsisting in the product/system or any other product/system
- the right of the Certificate holder to manufacture, supply, install, maintain or market the product/system
- individual installations of the product or system, including the nature, design, methods and workmanship of or related to the installation
- the actual works in which the product/system is installed, used and maintained, including the nature, design, methods and workmanship of such works.

19.5 Any information relating to the manufacture, supply, installation, use and maintenance of this product/system which is contained or referred to in this Certificate is the minimum required to be met when the product/system is manufactured, supplied, installed, used and maintained. It does not purport in any way to restate the requirements of the Health & Safety at Work etc Act 1974, or of any other statutory, common law or other duty which may exist at the date of this Certificate or in the future; nor is conformity with such information to be taken as satisfying the requirements of the 1974 Act or of any present or future statutory, common law or other duty of care. In granting this Certificate, the BBA does not accept responsibility to any person or body for any loss or damage, including personal injury, arising as a direct or indirect result of the manufacture, supply, installation, use and maintenance of this product/system.



In the opinion of the British Board of Agrément, Kooltherm K8 Cavity Board is fit for its intended use provided it is installed, used and maintained as set out in this Certificate. Certificate No 94/3047 is accordingly awarded to Kingspan Insulation Limited.

On behalf of the British Board of Agrément

Date of Third issue: 20th December 2006

Chief Executive

**Original Certificate issued 1st August 1994. This amended version includes revised declared thermal conductivity values, reference to revised Regulations and Standards and new Conditions of Certification.*



KOOLTHERM K8 CAVITY BOARD (BBA CERTIFICATE No 94/3047)

IRISH BUILDING REGULATIONS STATEMENT

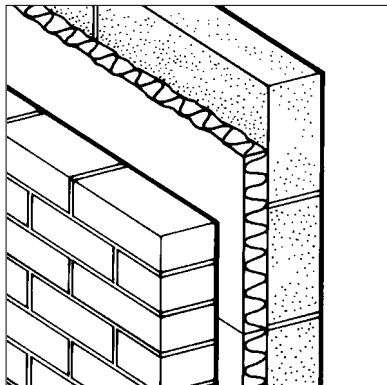

- THIS STATEMENT RELATES TO KOOLTHERM K8 CAVITY BOARD AND SETS OUT THE OPINION OF THE BBA ON THE POSITION OF THE PRODUCT UNDER THE BUILDING REGULATIONS IN THE REPUBLIC OF IRELAND.
- It must be read in conjunction with BBA Certificate No 94/3047.
- It will remain valid provided BBA Certificate No 94/3047 is valid.

The Building Regulations 1997/2006 (Ireland)

In the opinion of the BBA, Kooltherm K8 Cavity Board, if used in accordance with the provisions of Certificate No 94/3047, will satisfy or contribute to satisfying the relevant requirements.

Requirement:	B3 (1)	Internal fire spread (structure)
Comment:		Walls incorporating the product can meet this Requirement. See sections 8.2 to 8.4 of BBA Certificate No 94/3047.
Requirement:	C4	Resistance to weather and ground moisture
Comment:		Walls incorporating the product can meet this Requirement. See sections 7.2 and 10.2 of BBA Certificate No 94/3047. In addition the product may be used in situations where it bridges the dpc. See section 10.1 of BBA Certificate No 94/3047.
Requirement:	D1	Materials and workmanship
Comment:		The product is a proper material. See sections 13.1, 13.3 and 14 of BBA Certificate No 94/3047.
Requirement:	L1	Conservation of fuel and energy
Comment:		The product can meet or contribute to meeting the Elemental U value requirements for buildings and can contribute to a dwelling meeting the Overall Heat Loss or Heat Energy Rating method of compliance. See sections 12.3 to 12.6 of BBA Certificate No 94/3047.

On behalf of the British Board of Agrément

Date of issue: 9th January 2007

Chief Executive